

SUBMITTAL DATA

Flexmaster U.S.A.® STOD-BO3 UT 3000G

SHEET METAL FITTINGS

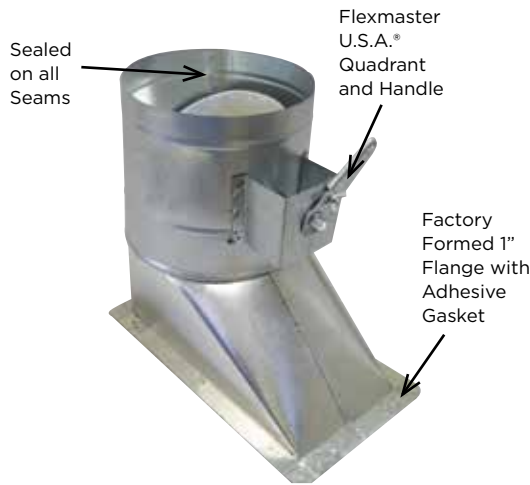

The Flexmaster U.S.A.® STOD-BO3 UT 3000G fitting is a factory sealed fitting, manufactured from 26 gauge, or heavier, galvanized steel to meet SMACNA and UMC Standards for commercial construction.

The STOD-BO3 UT 3000G is manufactured with a 1" formed on flange and Stick on Gasket to provide air-tight installation. It comes with Duro Dyne Open End Bearing and Closed End Bearing, a 2" stool, aluminum rod, and locking quadrant to provide easy access and system balancing when installed in a 1 1/2" thick Insulation Wrapped Duct System.

The STOD-BO3 UT 3000G should be installed using current SMACNA installation standards.

Features

- 26 gauge G90 Galvanized Steel Body
- 24 gauge G90 Galvanized Steel Damper
- Duro Dyne SB138 Open End Bearing and SB 338 Closed End Bearing
- Factory Formed Flange with Double Sided Adhesive Gasket
- Factory Sealed Seams and Duro Dyne Components
- 3/8" Square Aluminum Axle Secured to Damper with U-Bolts
- 2" Insulation Build Out
- Locking Hand Quadrant with Flexmaster U.S.A. Handle

(BO3 Designation consists of 3/8" Aluminum Axle, 2" Build Out and Locking Quadrant)

| Order Size | Diameter | Height | Width | Length |
|------------|----------|--------|-------|--------|
| 6" | 5 7/8" | 13" | 5" | 9" |
| 7" | 6 7/8" | 13" | 5" | 11" |
| 8" | 7 7/8" | 13" | 6" | 12" |
| 9" | 8 7/8" | 13" | 7" | 13" |
| 10" | 9 7/8" | 13" | 8" | 14" |
| 12" | 11 7/8" | 13" | 10" | 16" |
| 14" | 13 7/8" | 13" | 12" | 18" |
| 15" | 14 7/8" | 13" | 13" | 19" |
| 16" | 15 7/8" | 13" | 14" | 20" |
| 18" | 17 7/8" | 13" | 16" | 22" |
| 20" | 19 7/8" | 13" | 18" | 24" |

(+/-) 1/8" Tolerance on all Sizes.

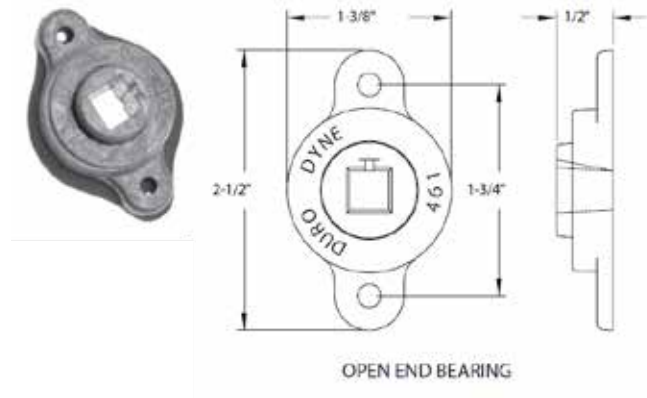
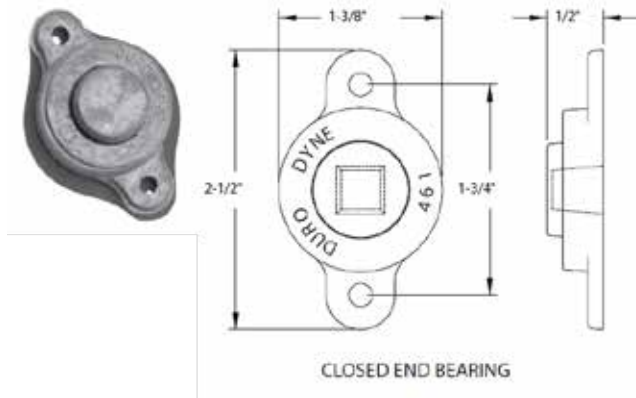

Flexmaster U.S.A.®
 5235 Ted Street
 Houston, TX 77040 USA
 Tel. +1.713.462.7694
 Fax +1.713.939.8441
 www.FlexmasterUSA.com
 www.Masterduct.com

FLEXMASTER U.S.A.®
 A MASTERDUCT COMPANY