

SUBMITTAL DATA

Flexmaster U.S.A.® 6M

Acoustical Flexible Duct Insulated

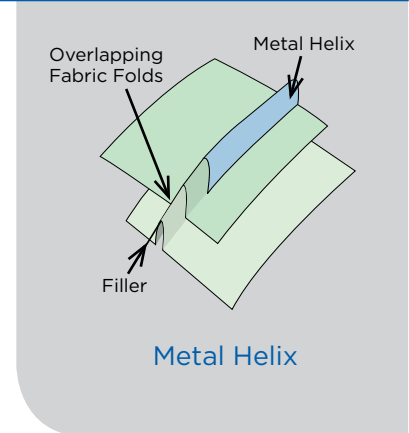
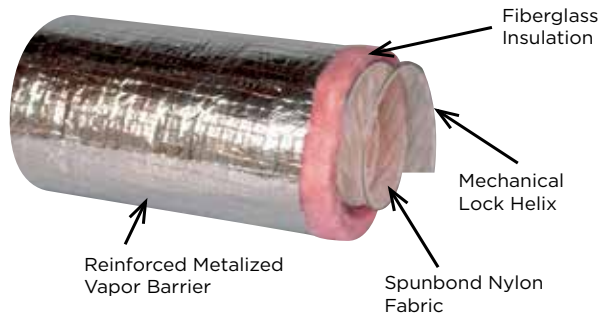

Technical Data	
Standard Lengths (ft)	25 ft, Special lengths on request
Inside Diameter (in)	3", 4", 5", 6", 7", 8", 9", 10", 12", 14", 15", 16", 18", 20"
Air Friction Loss	See Friction Loss Chart for details
Vapor Barrier Permeance	(.05) perm A.S.T.M. E96, Procedure A
Test Standard	UL181
Tested By	Intertek/ETL
Certifications Met	Class 1 Air Duct, NFPA 90A and 90B, BOCA, SBBC, HUD/FHA, MIN Property Std.
Internal Working Pressure (w.g.)	6" w.g. positive 5" w.g. negative thru 16" dia. 1" w.g. negative, 18" & 20" dia.
Rated Velocity	5500 F.P.M.
Min Burst Pressure	2 1/2 times working pressure
Operating Temperature Range	-20° to +250°F
Flame/Smoke	25/50
Insulation Thermal Conductance	R4.2, R6, R8
<p>Like the UL Mark, the ETL Listed Mark shows that our product has been independently tested by a Nationally Recognized Testing Laboratory (NRTL). It shows that it has met the requirements of widely accepted product safety standards and that we have agreed to periodic follow-up inspections to verify continued compliance.</p>	

Construction Features

The Flexmaster U.S.A.® Type 6M is manufactured to meet the highest quality standards in strength, permeability and fire resistance required in a flexible duct. Tested to UL standard 181, this Class 1 Air Duct is fabricated with an acoustically transparent Spunbond Nylon inner film which allows broadband sound energy to penetrate the duct wall.

Duct Fabric

A Spunbond Nylon fabric, mechanically locked to the duct helix without the use of adhesives.

Duct Helix

Made from corrosive resistant galvanized steel, the duct helix is mechanically formed to attach the duct fabric without the use of adhesives.

Vapor Barrier

Fire retardant, reinforced aluminum material. Excellent strength at low temperatures. Will not age harden.

Insulation

Formaldehyde-free fiberglass insulation by Johns Manville.

Flexmaster U.S.A.® Type 6 Acoustical Performance Submittal Data

Sound Attenuation - Straight Duct

Flexmaster U.S.A. Flexible Duct	Dia (in.)	Length (ft.)	Insertion Loss, dB Octave Band Center Frequency, Hz						
			63	125	250	500	1,000	2,000	4,000
Type 6	6	12	6.9	36	43	45	47	53	46
		9	5.5	24	28	29	30	33	29
		6	4.0	13	15	15	16	17	16
		3	2.3	4.9	5.3	5.3	5.5	5.8	5.4
		1	0.85	1.36	1.51	1.44	1.55	1.51	1.45
Type 6	8	12	11.3	39	37	46	49	55	49
		9	8.5	25	24	29	31	34	31
		6	5.7	14	13	15	16	18	16
		3	2.9	5.0	4.9	5.4	5.6	5.8	5.6
		1	0.98	1.39	1.37	1.45	1.48	1.52	1.48
Type 6	12	12	10.0	35	33	43	44	55	36
		9	8.1	23	22	28	28	34	24
		6	5.5	13	12	15	15	18	13
		3	2.8	4.8	4.7	5.3	5.3	5.8	4.9
		1	0.96	1.34	1.33	1.43	1.44	1.53	1.36

Sound Attenuation - 90° Elbow

Flexmaster U.S.A. Flexible Duct	Dia (in.)	Length (ft.)	Insertion Loss, dB Octave Band Center Frequency, Hz						
			63	125	250	500	1K	2K	4K
Type 6	6	12	21	46	47	52	56	55	55
		9	14	29	30	32	35	34	35
		6	9	15	16	17	18	17	18
		3	3.8	5.4	5.5	5.7	5.9	5.8	5.9
Type 6	8	12	25	44	50	55	50	56	57
		9	17	28	32	34	32	35	36
		6	10	15	16	17	16	18	18
		3	2.4	5.3	5.6	5.8	5.6	5.9	6.0
Type 6	12	12	29	40	43	47	46	49	43
		9	19	26	28	30	29	31	28
		6	11	14	15	16	15	16	15
		3	4.4	5.1	5.3	5.5	5.4	5.6	5.3

Notes:

1. Acoustical testing was performed in accordance with ASTM E477 and ADC Test Code FD 72-RI by ETL.
2. Insertion loss values are for flow velocities less than 2,500 fpm.
3. The 63 Hz IL values were laboratory measured, but were not published due to lack of acoustical value.