

Flexmaster U.S.A.®, Masterduct, Inc's HVAC Division
5235 Ted Street, Houston, Texas 77040
Ph. 713.462.7694 Fx. 713. 939.8441
www.flexmasterusa.com

Item # 41650

Flexmaster USA duct support by FlexRight®:

Designed to form flexible duct into highly efficient 90 degree elbows.

Universal Mount, 1 piece fully adjustable radius forming brace to support 4" inch (102-mm) through 16" inch (406mm) diameter flexible air ducts.

Nylon cable ties secure duct to duct support, (purchased separately and available from Flexmaster U.S.A.®)

Made from 100% recycled material (copolymer polypropylene)

UL 2043 Listed. <http://flexright.net/docs/specifications.php>

Meets ASHRAE's Advanced Energy Design Guides for Schools, warehouses, office and retail buildings.

The FlexRight® flexible duct elbow is manufactured by Build Right Products. Please see their website www.flexright.net for further details.

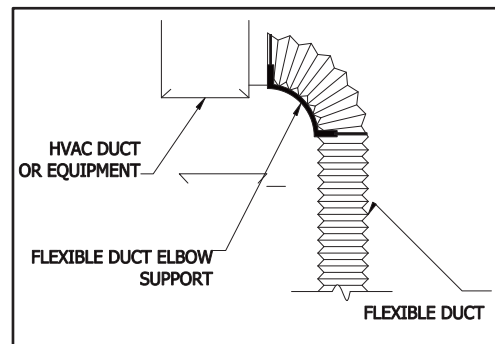
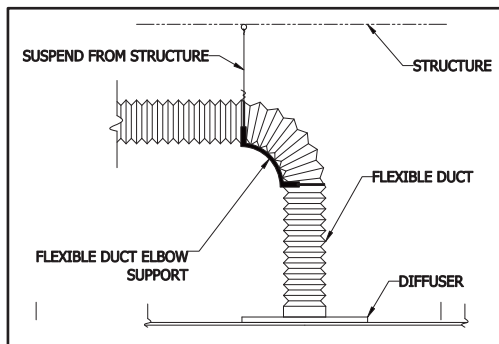
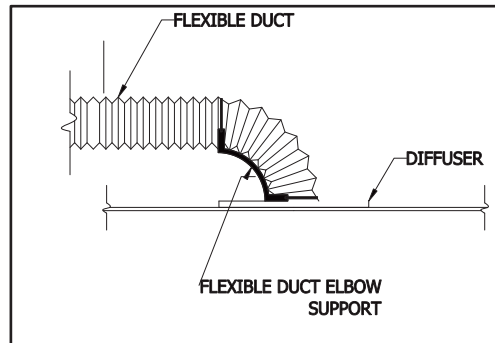
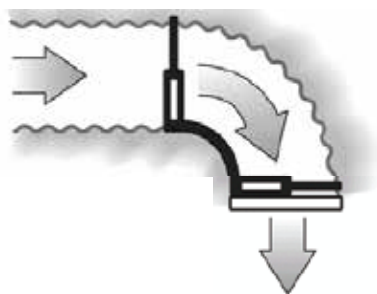

Installation Instructions:

- Step 1.** Install flexible duct over air device per flexible duct manufacturer's installation instructions.
- Step 2.** Thread cable ties through both FlexRight® saddle bands. *Cable ties not included.*
- Step 3.** Position one end of FlexRight® elbow around neck of air device and the other under the flexible duct to form 90° elbow. For best results, keep duct insulation out from under cable tie as it is tightened.
- Step 4.** Using cable tie tensioning tool, fasten cable tie around neck of air device to secure FlexRight®.
- Step 5.** Fasten second cable tie around flexible duct. *Do not over-tighten*, as to crush the flexible duct.
- Step 6.** Cut-off and discard excess from both cable tie ends.

